

# Product data sheet

Specifications



variable speed drive, Altivar Process ATV900, ATV930, 1.5kW, 400 to 480V, with braking unit, IP21 [TAA, BAA, BABA]

ATV930U15N4

**Product availability: Stock - Normally stocked in distribution facility**

## Main

<b>Range of Product</b>	Altivar Process ATV900
<b>Device Application</b>	Industrial Application
<b>Product or Component Type</b>	Variable speed drive
<b>Product destination</b>	Asynchronous motors Synchronous motors
<b>Product Specific Application</b>	Process for industrial
<b>Variant</b>	With braking chopper Standard version
<b>Phase</b>	3 phase
<b>Mounting Mode</b>	Wall mount
<b>Communication Port Protocol</b>	Modbus TCP EtherNet/IP Modbus serial
<b>[Us] rated supply voltage</b>	380...480 V - 15...10 %
<b>Continuous output current</b>	4 A 4 kHz normal duty 2.2 A 4 kHz heavy duty
<b>EMC filter</b>	Integrated With EMC plate option
<b>IP degree of protection</b>	IP21
<b>Degree of protection</b>	UL type 1
<b>option module</b>	Slot A communication module Profibus DP V1 Slot A communication module PROFINET Slot A communication module DeviceNet Slot A communication module EtherCAT Slot A communication module CANopen daisy chain RJ45 Slot A communication module CANopen SUB-D 9 Slot A communication module CANopen screw terminals Slot A/slot B/slot C digital and analog I/O extension module Slot A/slot B/slot C output relay extension module Slot B 5/12 V digital encoder interface module Slot B analog encoder interface module Slot B resolver encoder interface module communication module Ethernet Powerlink
<b>Discrete input logic</b>	16 preset speeds
<b>Motor power kW</b>	1.5 kW normal duty 0.75 kW heavy duty
<b>Asynchronous motor control profile</b>	Constant torque standard Optimized torque mode Variable torque standard
<b>Synchronous motor control profile</b>	Permanent magnet motor Synchronous reluctance motor

Price is "List Price" and may be subject to a trade discount – check with your local distributor or retailer for actual price.

<b>Maximum output frequency</b>	599 Hz
<b>Switching frequency</b>	2...16 kHz adjustable 4...16 kHz with derating factor
<b>Nominal switching frequency</b>	4 kHz
<b>Line current</b>	3.0 A 380 V normal duty) 1.7 A 380 V heavy duty) 2.6 A 480 V normal duty) 1.5 A 480 V heavy duty)
<b>Apparent power</b>	2.2 kVA 480 V normal duty) 1.2 kVA 480 V heavy duty)
<b>Maximum transient current</b>	4.8 A 60 s normal duty) 3.3 A 60 s heavy duty)
<b>Network Frequency</b>	50-60 Hz
<b>Prospective line Isc</b>	50 kA

## Complementary

<b>Discrete input number</b>	10
<b>Discrete input type</b>	DI1...DI8 programmable, 24 V DC $\leq$ 30 V)3.5 kOhm DI7, DI8 programmable as pulse input 0...30 kHz, 24 V DC $\leq$ 30 V) STOA, STOB safe torque off, 24 V DC $\leq$ 30 V) $>$ 2.2 kOhm
<b>Discrete output number</b>	2
<b>Discrete output type</b>	Logic output DQ+ 0...1 kHz $\leq$ 30 V DC 100 mA Programmable as pulse output DQ+ 0...30 kHz $\leq$ 30 V DC 20 mA Logic output DQ- 0...1 kHz $\leq$ 30 V DC 100 mA
<b>Analogue input number</b>	3
<b>Analogue input type</b>	AI1, AI2, AI3 software-configurable voltage 0...10 V DC 30 kOhm 12 bits AI1, AI2, AI3 software-configurable current 0...20 mA/4...20 mA 250 Ohm 12 bits
<b>Analogue output number</b>	2
<b>Analogue output type</b>	Software-configurable voltage AQ1, AQ2 0...10 V DC 470 Ohm 10 bits Software-configurable current AQ1, AQ2 0...20 mA 500 Ohm 10 bits
<b>Relay output number</b>	3
<b>Relay output type</b>	Configurable relay logic R1 fault relay NO/NC 100000 cycles Configurable relay logic R2 sequence relay NO 1000000 cycles Configurable relay logic R3 sequence relay NO 1000000 cycles
<b>Maximum switching current</b>	Relay output R1 resistive, $\cos \phi = 1$ 3 A 250 V AC Relay output R1 resistive, $\cos \phi = 1$ 3 A 30 V DC Relay output R1 inductive, $\cos \phi = 0.4$ 7 ms 2 A 250 V AC Relay output R1 inductive, $\cos \phi = 0.4$ 7 ms 2 A 30 V DC Relay output R2, R3 resistive, $\cos \phi = 1$ 5 A 250 V AC Relay output R2, R3 resistive, $\cos \phi = 1$ 5 A 30 V DC Relay output R2, R3 inductive, $\cos \phi = 0.4$ 7 ms 2 A 250 V AC Relay output R2, R3 inductive, $\cos \phi = 0.4$ 7 ms 2 A 30 V DC
<b>Minimum switching current</b>	Relay output R1, R2, R3 5 mA 24 V DC
<b>Physical interface</b>	Ethernet 2-wire RS 485
<b>Connector Type</b>	2 RJ45 1 RJ45
<b>Method of access</b>	Slave Modbus TCP
<b>Transmission Rate</b>	10, 100 Mbits 4.8 kbps 9600 bit/s 19200 bit/s
<b>Transmission frame</b>	RTU
<b>Number of addresses</b>	1...247

<b>Data format</b>	8 bits, configurable odd, even or no parity
<b>Type of polarization</b>	No impedance
<b>4 quadrant operation possible</b>	True
<b>Acceleration and deceleration ramps</b>	Linear adjustable separately from 0.01...9999 s
<b>Motor slip compensation</b>	Adjustable Can be suppressed Automatic whatever the load Not available in permanent magnet motor law
<b>Braking to standstill</b>	By DC injection
<b>Brake chopper integrated</b>	True
<b>Maximum Input Current per Phase</b>	3.0 A
<b>Maximum output voltage</b>	480.0 V
<b>Relative symmetric network frequency tolerance</b>	5 %
<b>Base load current at high overload</b>	2.2 A
<b>Base load current at low overload</b>	4.0 A
<b>Power dissipation in W</b>	Natural convection 28 W 380 V 4 kHz Forced convection 41 W 380 V 4 kHz
<b>With safety function Safely Limited Speed (SLS)</b>	True
<b>With safety function Safe brake management (SBC/SBT)</b>	True
<b>With safety function Safe Operating Stop (SOS)</b>	False
<b>With safety function Safe Position (SP)</b>	False
<b>With safety function Safe programmable logic</b>	False
<b>With safety function Safe Speed Monitor (SSM)</b>	False
<b>With safety function Safe Stop 1 (SS1)</b>	True
<b>With sft fct Safe Stop 2 (SS2)</b>	False
<b>With safety function Safe torque off (STO)</b>	True
<b>With safety function Safely Limited Position (SLP)</b>	False
<b>With safety function Safe Direction (SDI)</b>	False
<b>Protection type</b>	Thermal protection motor Safe torque off motor Motor phase break motor Thermal protection drive Safe torque off drive Overheating drive Overcurrent between output phases and earth drive Overload of output voltage drive Short-circuit protection drive Motor phase break drive Overvoltages on the DC bus drive Line supply overvoltage drive Line supply undervoltage drive Line supply phase loss drive Overspeed drive Break on the control circuit drive
<b>Quantity per Set</b>	1
<b>Width</b>	5.7 in (144 mm)
<b>Height</b>	13.8 in (350 mm)
<b>Depth</b>	8.1 in (206 mm)

<b>Net Weight</b>	9.9 lb(US) (4.5 kg)
<b>Electrical connection</b>	Control screw terminal 0.5...1.5 mm <sup>2</sup> AWG 20...AWG 16 Line side screw terminal 2.5...6 mm <sup>2</sup> AWG 14...AWG 10 Motor screw terminal 2.5...6 mm <sup>2</sup> AWG 14...AWG 10 DC bus screw terminal 2.5...6 mm <sup>2</sup> AWG 14...AWG 10
<b>Transmission Rate</b>	10/100 Mbit/s Ethernet IP/Modbus TCP 4.8, 9.6, 19.2, 38.4 kbit/s Modbus serial
<b>Exchange mode</b>	Half duplex, full duplex, autonegotiation Ethernet IP/Modbus TCP
<b>Data format</b>	8 bits, configurable odd, even or no parity Modbus serial
<b>Type of polarization</b>	No impedance Modbus serial
<b>Number of addresses</b>	1...247 Modbus serial
<b>Supply</b>	External supply for digital inputs 24 V DC 19...30 V), <1.25 mA overload and short-circuit protection Internal supply for reference potentiometer (1 to 10 kOhm) 10.5 V DC +/- 5 %, <10 mA overload and short-circuit protection Internal supply for digital inputs and STO 24 V DC 21...27 V), <200 mA overload and short-circuit protection
<b>Local signalling</b>	Local diagnostic 3 LED mono/dual colour) Embedded communication status 5 LED dual colour) Communication module status 2 LED dual colour) Presence of voltage 1 LED red)
<b>Input compatibility</b>	DI1...DI8 discrete input level 1 PLC IEC 61131-2 DI7, DI8 pulse input level 1 PLC IEC 65A-68 STOA, STOB discrete input level 1 PLC IEC 61131-2
<b>Discrete input logic</b>	Positive logic (source) DI1...DI8), < 5 V, > 11 V Negative logic (sink) DI1...DI8), > 16 V, < 10 V Positive logic (source) DI7, DI8), < 0.6 V, > 2.5 V Positive logic (source) STOA, STOB), < 5 V, > 11 V
<b>Sampling duration</b>	2 ms +/- 0.5 ms DI1...DI8) - discrete input 5 ms +/- 1 ms DI7, DI8) - pulse input 1 ms +/- 1 ms AI1, AI2, AI3) - analog input 5 ms +/- 1 ms AQ1, AQ2) - analog output
<b>Accuracy</b>	+/- 0.6 % AI1, AI2, AI3 for a temperature variation 60 °C analog input +/- 1 % AQ1, AQ2 for a temperature variation 60 °C analog output
<b>Linearity error</b>	AI1, AI2, AI3 +/- 0.15 % of maximum value analog input AQ1, AQ2 +/- 0.2 % analog output
<b>Refresh time</b>	Relay output R1, R2, R3)5 ms +/- 0.5 ms)
<b>Isolation</b>	Between power and control terminals

## Environment

<b>Operating altitude</b>	<= 3280.84 ft (1000 m) without derating 1000...4800 m with current derating 1 % per 100 m
<b>Operating position</b>	Vertical +/- 10 degree
<b>Product Certifications</b>	TÜV CSA UL
<b>Marking</b>	CE
<b>Standards</b>	UL 508C IEC 61800-3 IEC 61800-5-1 IEC 61000-3-12 IEC 60721-3 IEC 61508 IEC 13849-1
<b>Maximum THDI</b>	<48 % full load IEC 61000-3-12
<b>Assembly style</b>	Enclosed

<b>Electromagnetic compatibility</b>	Electrostatic discharge immunity test level 3 conforming to IEC 61000-4-2 Radiated radio-frequency electromagnetic field immunity test level 3 conforming to IEC 61000-4-3 Electrical fast transient/burst immunity test level 4 conforming to IEC 61000-4-4 1.2/50 $\mu$ s - 8/20 $\mu$ s surge immunity test level 3 conforming to IEC 61000-4-5 Conducted radio-frequency immunity test level 3 conforming to IEC 61000-4-6
<b>Environmental class (during operation)</b>	Class 3C3 according to IEC 60721-3-3 Class 3S3 according to IEC 60721-3-3
<b>Maximum acceleration under shock impact (during operation)</b>	150 m/s <sup>2</sup> at 11 ms
<b>Maximum acceleration under vibrational stress (during operation)</b>	10 m/s <sup>2</sup> at 13...200 Hz
<b>Maximum deflection under vibratory load (during operation)</b>	1.5 mm at 2...13 Hz
<b>Permitted relative humidity (during operation)</b>	Class 3K5 according to EN 60721-3
<b>Volume of cooling air</b>	10038.7 Gal/hr(US) (38 m <sup>3</sup> /h)
<b>Overvoltage category</b>	III
<b>Regulation loop</b>	Adjustable PID regulator
<b>Insulation resistance</b>	> 1 MOhm 500 V DC for 1 minute to earth
<b>Noise level</b>	54.5 dB 86/188/EEC
<b>Vibration resistance</b>	1.5 mm peak to peak (f= 2...13 Hz) conforming to IEC 60068-2-6 1 gn (f= 13...200 Hz) conforming to IEC 60068-2-6
<b>Shock resistance</b>	15 gn 11 ms IEC 60068-2-27
<b>Environmental characteristic</b>	Chemical pollution resistance class 3C3 IEC 60721-3-3 Dust pollution resistance class 3S3 IEC 60721-3-3
<b>Relative humidity</b>	5...95 % without condensation IEC 60068-2-3
<b>Ambient air temperature for operation</b>	5...122 °F (-15...50 °C) (without derating) 122...140 °F (50...60 °C) (with derating factor)
<b>Noise level</b>	54.5 dB
<b>pollution degree</b>	2
<b>Ambient air transport temperature</b>	-40...158 °F (-40...70 °C)
<b>Ambient Air Temperature for Storage</b>	-40...158 °F (-40...70 °C)

## Ordering and shipping details

<b>Category</b>	US1CP4E22276
<b>Discount Schedule</b>	CP4E
<b>GTIN</b>	3606480883262
<b>Returnability</b>	Yes
<b>Country of origin</b>	ID

## Packing Units

<b>Unit Type of Package 1</b>	PCE
<b>Number of Units in Package 1</b>	1
<b>Package 1 Height</b>	12.20 in (31.000 cm)
<b>Package 1 Width</b>	7.48 in (19.000 cm)
<b>Package 1 Length</b>	16.14 in (41.000 cm)
<b>Package 1 Weight</b>	12.994 lb(US) (5.894 kg)

<b>Unit Type of Package 2</b>	P06
<b>Number of Units in Package 2</b>	6
<b>Package 2 Height</b>	29.53 in (75.000 cm)
<b>Package 2 Width</b>	23.62 in (60.000 cm)
<b>Package 2 Length</b>	31.50 in (80.000 cm)
<b>Package 2 Weight</b>	105.394 lb(US) (47.806 kg)



## Environmental Data

Schneider Electric aims to achieve Net Zero status by 2050 through supply chain partnerships, lower impact materials, and circularity via our ongoing “Use Better, Use Longer, Use Again” campaign to extend product lifetimes and recyclability.

[Environmental Data explained >](#)

[How we assess product sustainability >](#)

### Environmental footprint

Carbon footprint (kg CO2 eq, Total Life cycle) **2670**

Environmental Disclosure [Product Environmental Profile](#)

## Use Better

### Materials and Substances

[EU RoHS Directive](#) Pro-active compliance (Product out of EU RoHS legal scope)

REACH Regulation [REACH Declaration](#)

California proposition 65 **WARNING:** This product can expose you to chemicals including: Lead and lead compounds, which is known to the State of California to cause cancer and birth defects or other reproductive harm. For more information go to [www.P65Warnings.ca.gov](http://www.P65Warnings.ca.gov)

### Energy efficiency

Product contributes to saved and avoided emissions **Yes**

## Use Again

### Repack and remanufacture

Circularity Profile [End of Life Information](#)

Take-back **No**

WEEE  **The product must be disposed on European Union markets following specific waste collection and never end up in rubbish bins.**

Dimensions Drawings

Dimensions

Right, Front and Rear View

mm  
in.

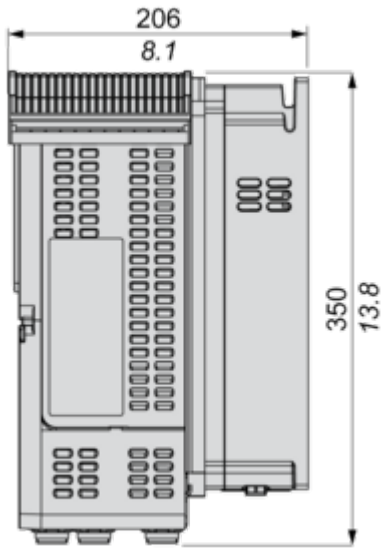

mm  
in.

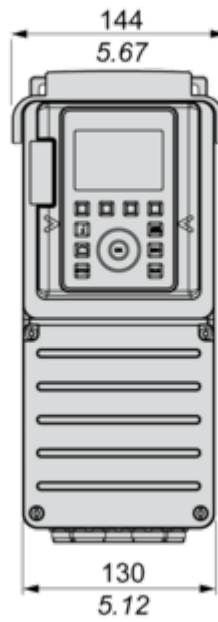

mm  
in.

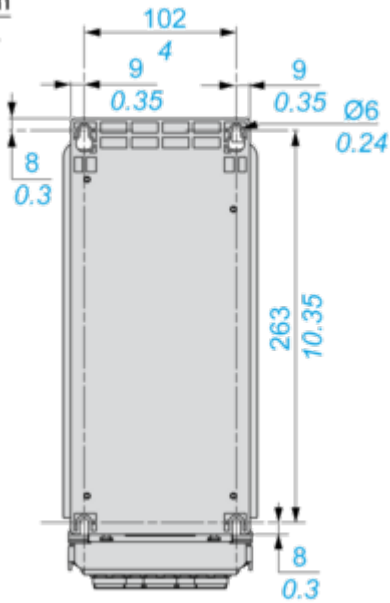

Mounting and Clearance

Clearances

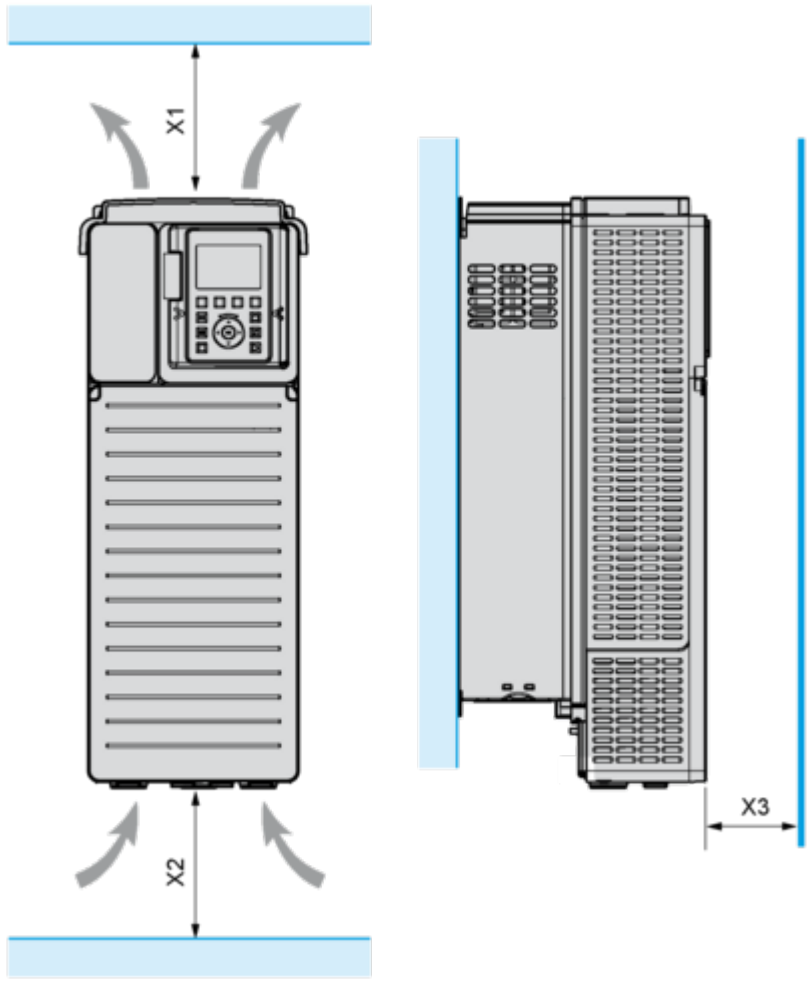

X1	X2	X3
≥ 100 mm (3.94 in.)	≥ 100 mm (3.94 in.)	≥ 10 mm (0.39 in.)

- Mount the device in a vertical position ( $\pm 10^\circ$ ). This is required for cooling the device.
- Do not mount the device close to heat sources.
- Leave sufficient free space so that the air required for cooling purposes can circulate from the bottom to the top of the drive.

Mounting Types

---

**Mounting Type A: Individual IP21**

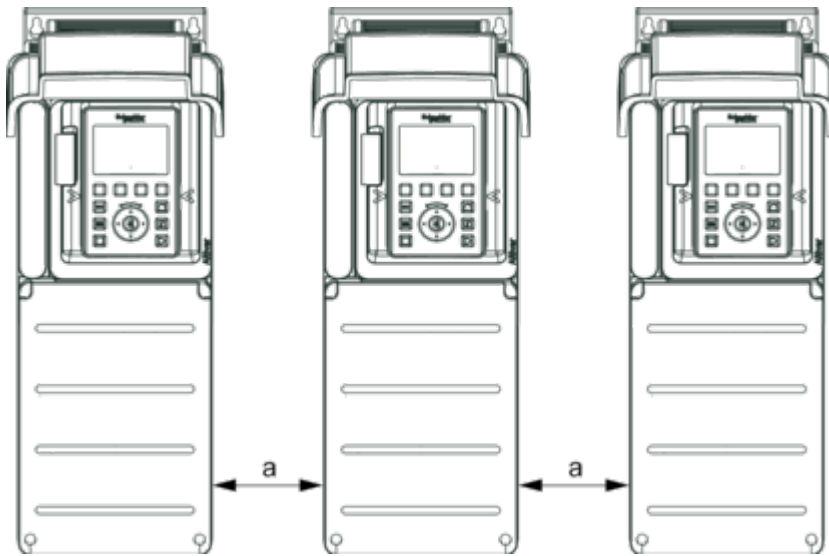

$a \geq 100 \text{ mm (3.94 in.)}$

**Mounting Type B: Side by Side IP20**

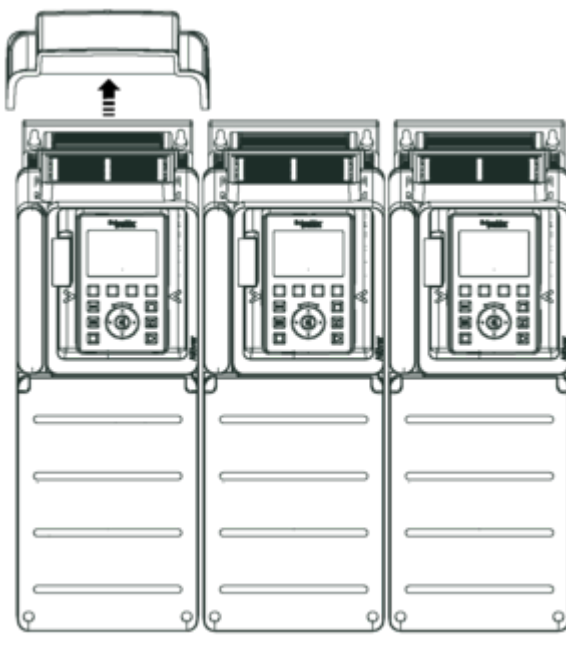

**Mounting Type C: Individual IP20**

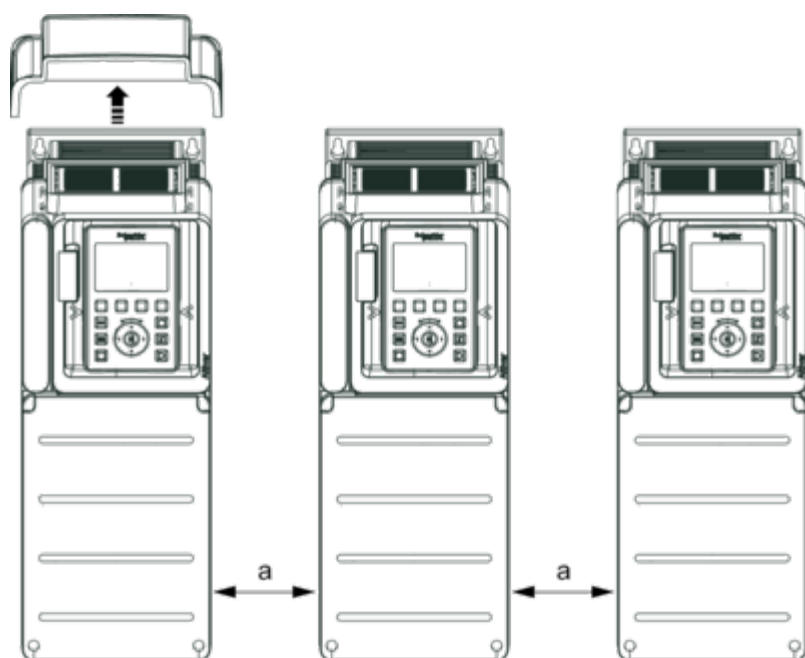

$a \geq 0$

Connections and Schema

**Three-Phase Power Supply with Upstream Breaking via Line Contactor**

Connection diagrams conforming to standards EN 954-1 category 1 and IEC/EN 61508 capacity SIL1, stopping category 0 in accordance with standard IEC/EN 60204-1

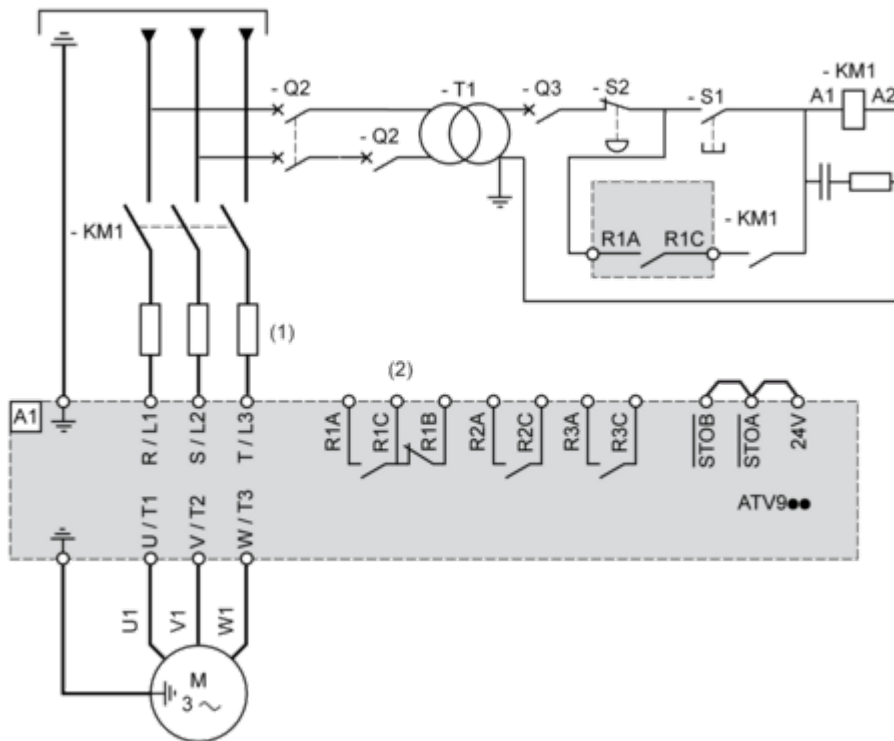

(1) Line choke if used

(2) Use relay R1 set to operating state Fault to switch Off the product once an error is detected.

A1 : Drive

KM1 : Line Contactor

Q2, Q3 : Circuit breakers

S1, S2 : Pushbuttons

T1 : Transformer for control part

**Three-Phase Power Supply with Downstream Breaking via Contactor**

Connection diagrams conforming to standards EN 954-1 category 1 and IEC/EN 61508 capacity SIL1, stopping category 0 in accordance with standard IEC/EN 60204-1

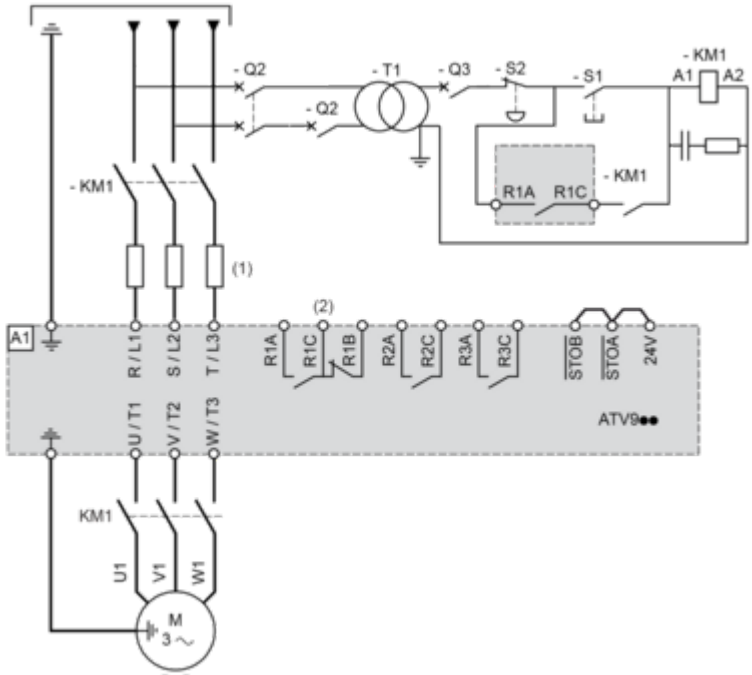

(1) Line choke if used

(2) Use relay R1 set to operating state Fault to switch Off the product once an error is detected.

A1 : Drive

KM1 : Contactor

Control Block Wiring Diagram

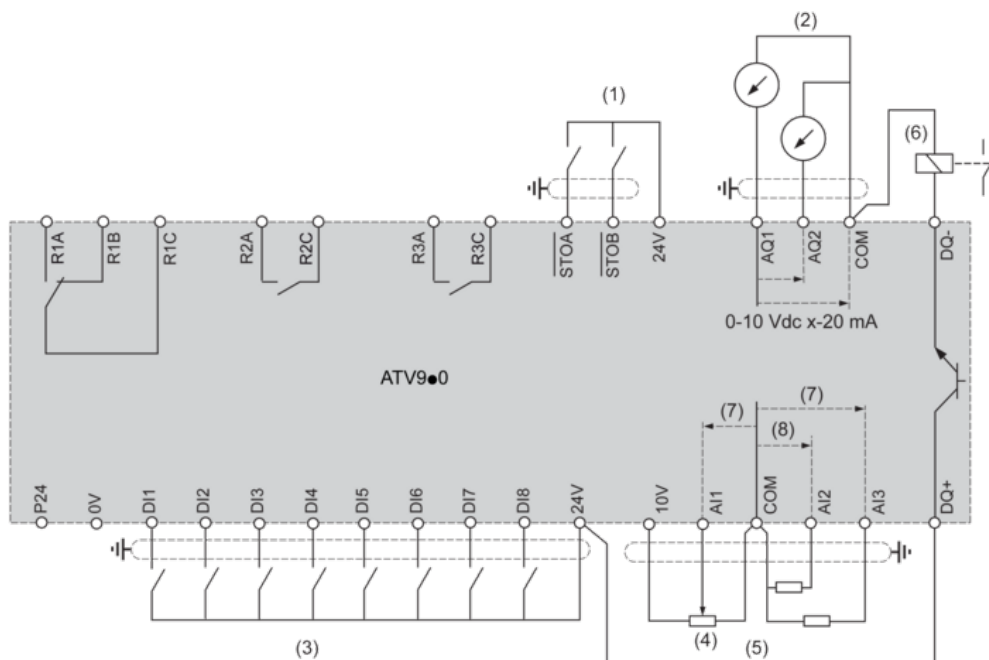

- (1) Safe Torque Off
  - (2) Analog Output
  - (3) Digital Input
  - (4) Reference potentiometer
  - (5) Analog Input
  - (6) Digital Output
  - (7) 0-10 Vdc, x-20 mA
  - (8) 0-10 Vdc, -10 Vdc...+10 Vdc
- R1A, R1B, R1C** : Fault relay  
**R2A, R2C** : Sequence relay  
**R3A, R3C** : Sequence relay

Sensor Connection

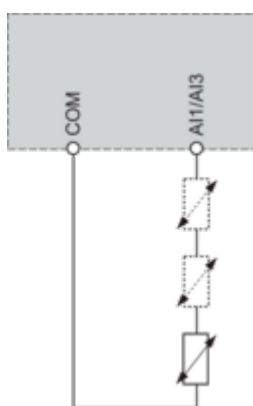

It is possible to connect either 1 or 3 sensors on terminals AI1 or AI3

**Sink / Source Switch Configuration**

The switch is used to adapt the operation of the logic inputs to the technology of the programmable controller outputs.

- Set the switch to Source (factory setting) if using PLC outputs with PNP transistors.
- Set the switch to Ext if using PLC outputs with NPN transistors.

**Switch Set to SRC (Source) Position Using the Output Power Supply for the Digital Inputs**

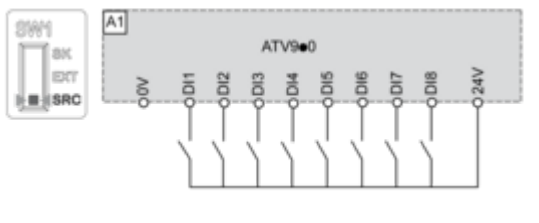

**Switch Set to SRC (Source) Position and Use of an External Power Supply for the DIs**

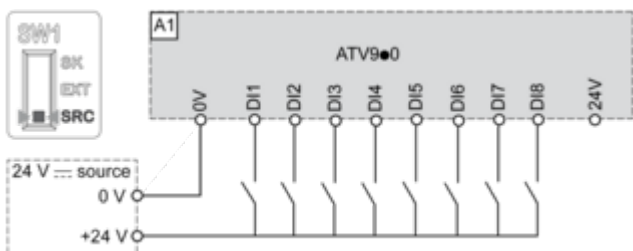

**Switch Set to SK (Sink) Position Using the Output Power Supply for the Digital Inputs**

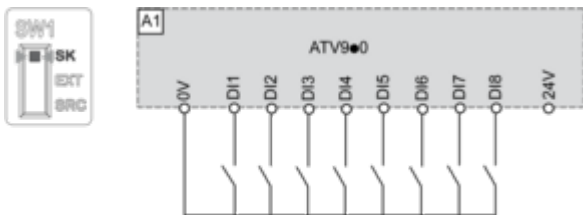

**Switch Set to EXT Position Using an External Power Supply for the DIs**

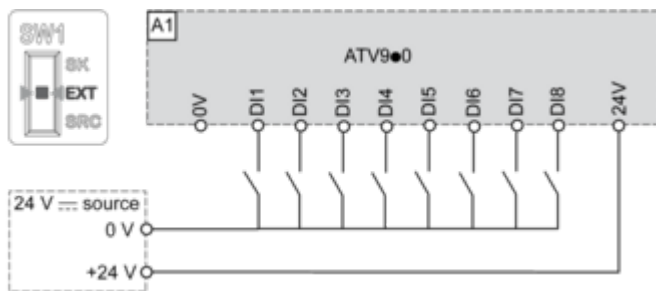

Performance Curves

Derating Curves

---

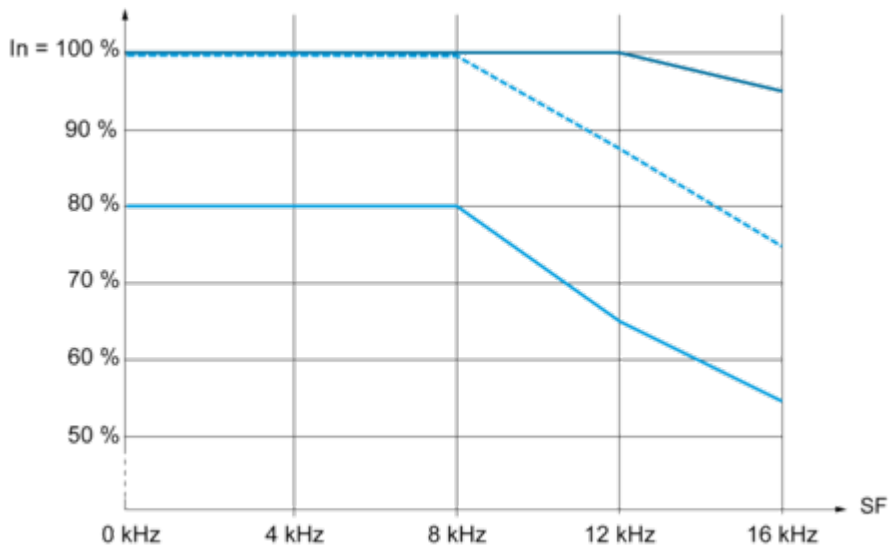

- 40 °C (104 °F) - Mounting type A, B and C
- 50 °C (122 °F) - Mounting type A, B and C
- 60 °C (140 °F) - Mounting type B and C

In : Nominal Drive Current

SF : Switching Frequency