

## TINA-Y-SS

~16° smooth spot beam. Assembly with holder, installation tape and pins.

### SPECIFICATION:

Dimensions	Ø 16.1
Height	10 mm
Fastening	tape, pin
ROHS compliant	yes ⓘ



### MATERIALS:

Component	Type	Material	Colour	Finish	Length (mm)
TINA-Y-SS	Single lens	PMMA	clear	gloss	
TINA-Y-HLD	Holder	PC	black	gloss	
TINA-Y-TAPE	Tape	Acrylic foam tape			

### ORDERING INFORMATION:

Component	Qty in box	MOQ	MPQ	Box weight (kg)
CA18103_TINA-Y-SS » Box size: 476 x 273 x 197 mm	3900	300	300	5.7

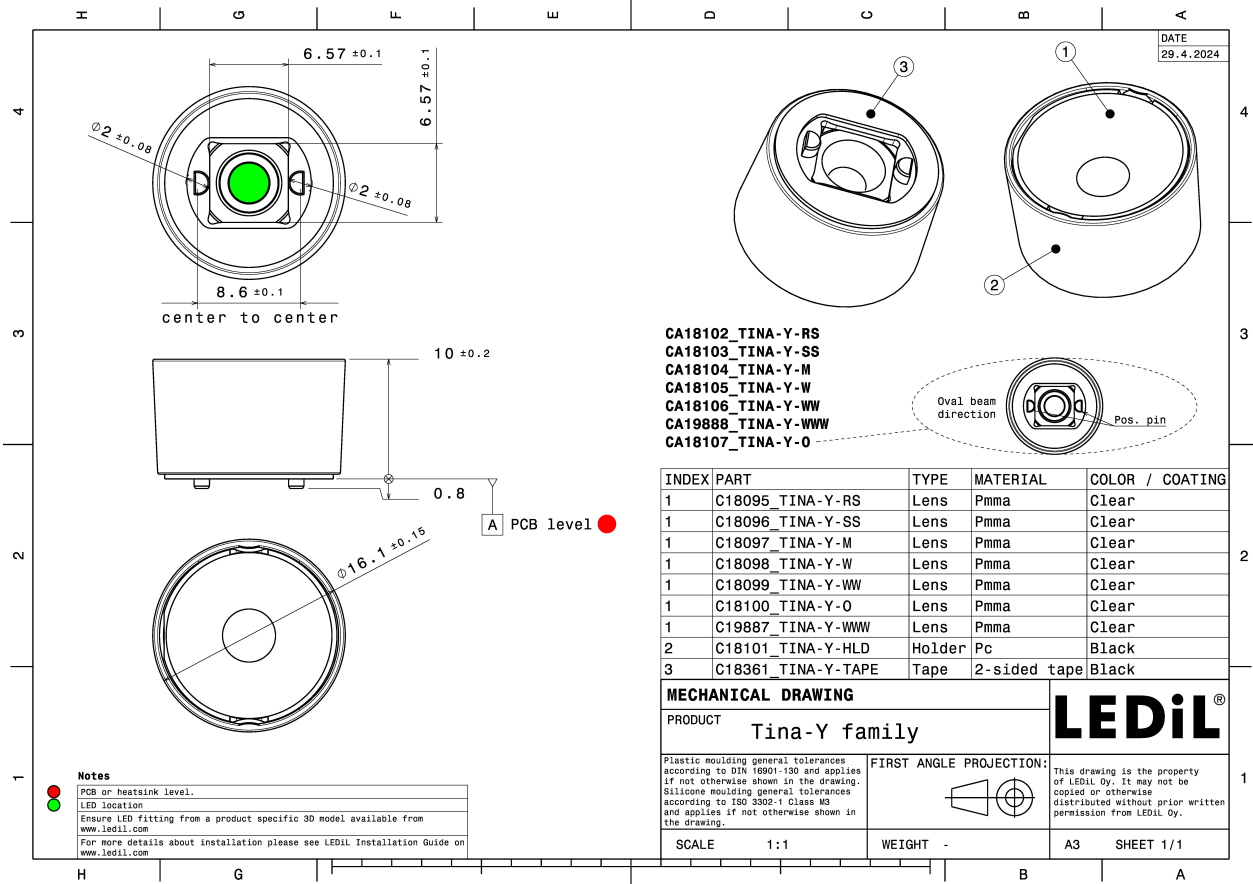

See also our general installation guide: [www.ledil.com/installation\\_guide](http://www.ledil.com/installation_guide)

#### OPTICAL RESULTS (MEASURED):



LED XP-G3  
 FWHM / FWTM 18.0° / 37.0°  
 Efficiency 81 %  
 Peak intensity 5.4 cd/lm  
 LEDs/each optic 1  
 Light colour/type White  
 Required components:

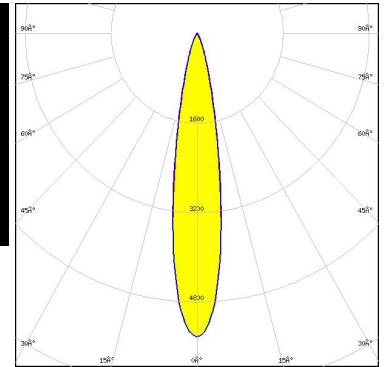

Light distribution files



LED XP-G4  
 FWHM / FWTM 17.0° / 33.0°  
 Efficiency 87 %  
 Peak intensity 7.1 cd/lm  
 LEDs/each optic 1  
 Light colour/type White  
 Required components:

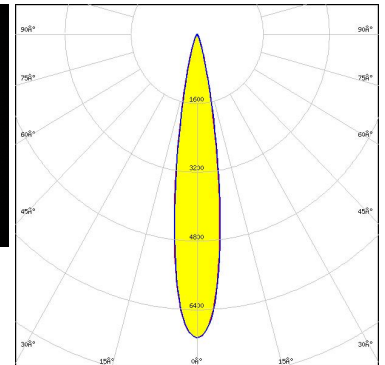
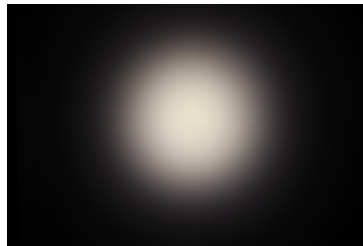

Light distribution files



LED NVSW719AC  
 FWHM / FWTM 17.0° / 31.0°  
 Efficiency 87 %  
 Peak intensity 7.9 cd/lm  
 LEDs/each optic 1  
 Light colour/type White  
 Required components:

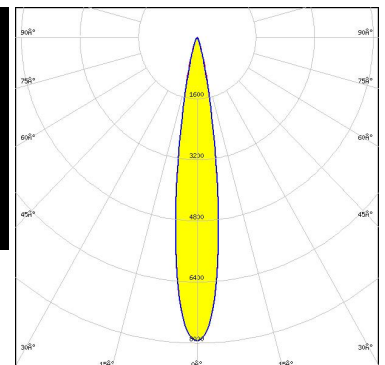

Light distribution files

#### OPTICAL RESULTS (MEASURED):

**OSRAM**  
Opto Semiconductors

LED OSCONIQ C 3030  
FWHM / FWTM 16.0° / 36.0°  
Efficiency 83 %  
Peak intensity 6.3 cd/lm  
LEDs/each optic 1  
Light colour/type White  
Required components:

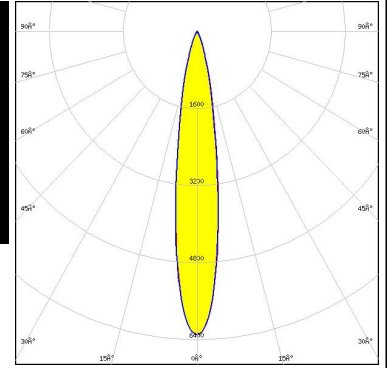

Light distribution files

#### OPTICAL RESULTS (SIMULATED):

**bridgelux**

LED	SMD 3535 BXEX-XXX-11H-3B1
FWHM / FWTM	18.0° / 35.0 + 34.0°
Efficiency	88 %
Peak intensity	6.3 cd/lm
LEDs/each optic	1
Light colour/type	White
Required components:	

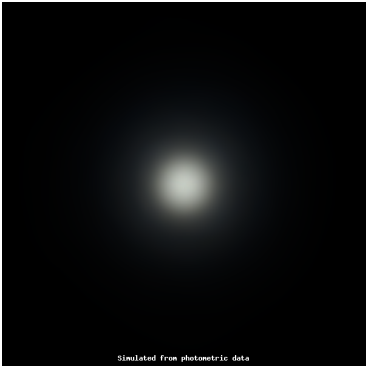
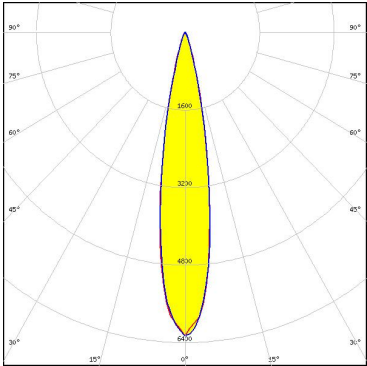
Light distribution files

**CREE LEDs**

LED	CLR6A-TKW
FWHM / FWTM	21.0° / 42.0°
Efficiency	86 %
Peak intensity	4.5 cd/lm
LEDs/each optic	1
Light colour/type	RGBW
Required components:	

Light distribution files

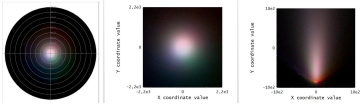
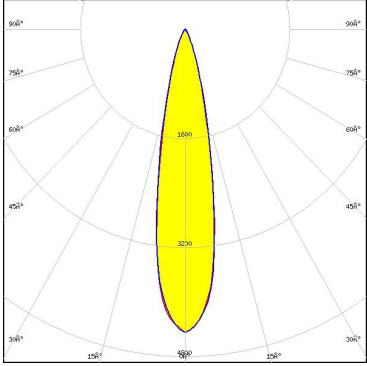
**CREE LEDs**

LED	J Series 3030C
FWHM / FWTM	16.0° / 34.0°
Efficiency	87 %
Peak intensity	7.3 cd/lm
LEDs/each optic	1
Light colour/type	White
Required components:	

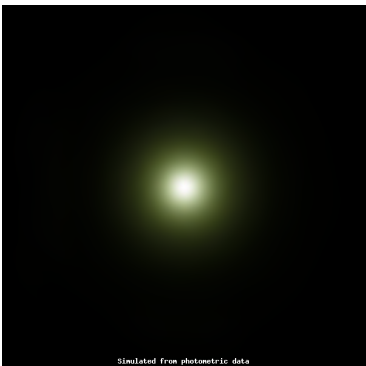

Light distribution files

### OPTICAL RESULTS (SIMULATED):



LED XD16 Premium  
FWHM / FWTM 14.0° / 26.0°  
Efficiency 86 %  
Peak intensity 11.4 cd/lm  
LEDs/each optic 1  
Light colour/type White  
Required components:

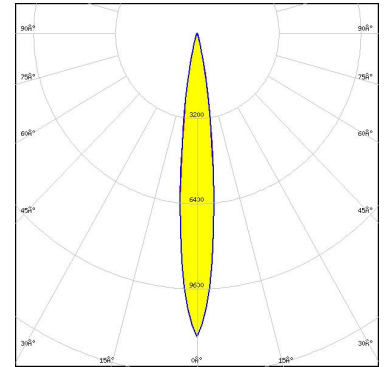

Light distribution files



LED XE-G  
FWHM / FWTM 16.0° / 28.0°  
Efficiency 87 %  
Peak intensity 9 cd/lm  
LEDs/each optic 1  
Light colour/type White  
Required components:

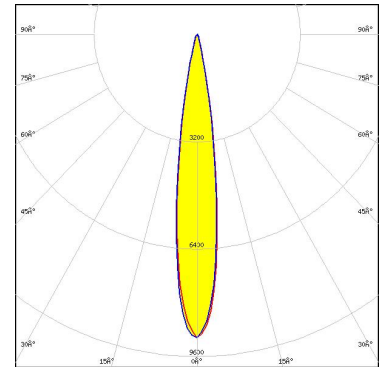

Light distribution files



LED XHP35.2 HD  
FWHM / FWTM 28.0° / 52.0°  
Efficiency 75 %  
Peak intensity 2.5 cd/lm  
LEDs/each optic 1  
Light colour/type White  
Required components:

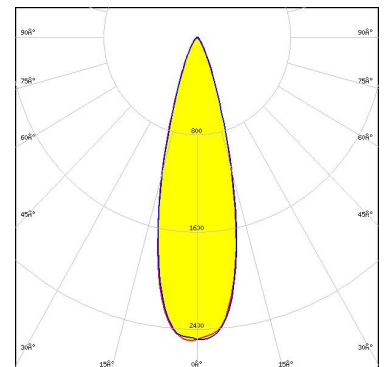

Light distribution files

### OPTICAL RESULTS (SIMULATED):



LED XHP35.2 HI  
FWHM / FWTM 22.0° / 46.0°  
Efficiency 83 %  
Peak intensity 3.8 cd/lm  
LEDs/each optic 1  
Light colour/type White  
Required components:

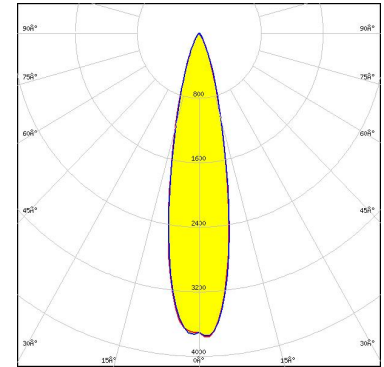

Light distribution files



LED XHP50.3 HI  
FWHM / FWTM 24.0° / 48.0°  
Efficiency 82 %  
Peak intensity 3.4 cd/lm  
LEDs/each optic 1  
Light colour/type White  
Required components:

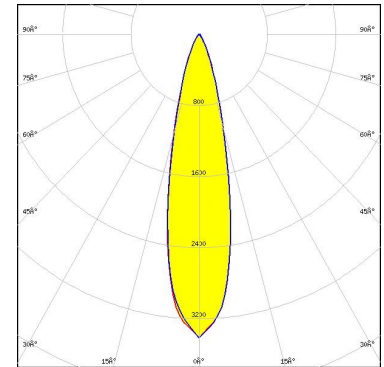

Light distribution files



LED XM-L RGBW (XMLDCL HD)  
FWHM / FWTM 30.0° / 50.0°  
Efficiency 85 %  
Peak intensity 2.7 cd/lm  
LEDs/each optic 1  
Light colour/type RGBW  
Required components:

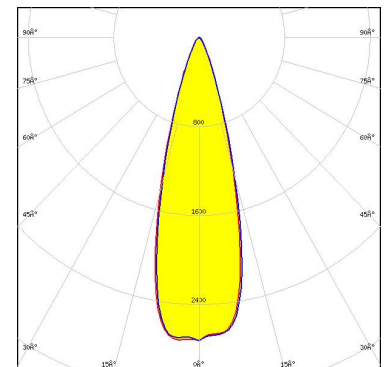

Light distribution files

#### OPTICAL RESULTS (SIMULATED):



LED XM-L RGBW (XMLDCL HI)  
 FWHM / FWTM 20.0° / 38.0°  
 Efficiency 85 %  
 Peak intensity 5.3 cd/lm  
 LEDs/each optic 1  
 Light colour/type RGBW  
 Required components:

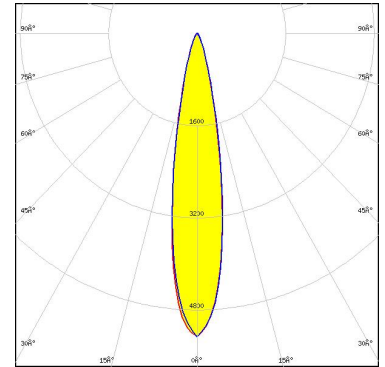

Light distribution files



LED XM-L3  
 FWHM / FWTM 21.0° / 42.0°  
 Efficiency 80 %  
 Peak intensity 4 cd/lm  
 LEDs/each optic 1  
 Light colour/type White  
 Required components:

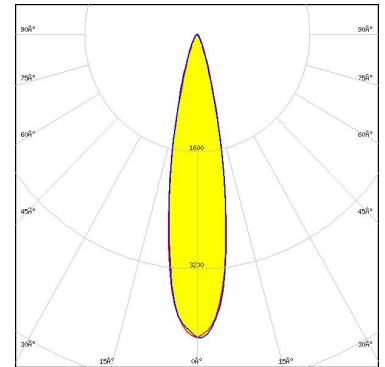

Light distribution files



LED XP-E2  
 FWHM / FWTM 12.0° / 24.0°  
 Efficiency 88 %  
 Peak intensity 13 cd/lm  
 LEDs/each optic 1  
 Light colour/type White  
 Required components:

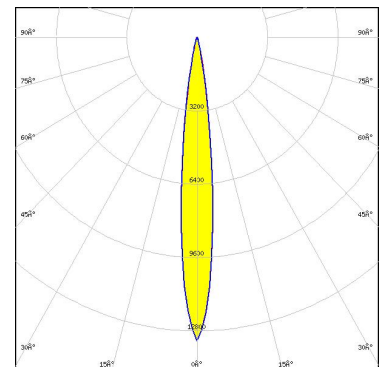

Light distribution files

#### OPTICAL RESULTS (SIMULATED):



LED XP-G2  
 FWHM / FWTM 15.0° / 28.0°  
 Efficiency 87 %  
 Peak intensity 9 cd/lm  
 LEDs/each optic 1  
 Light colour/type White  
 Required components:

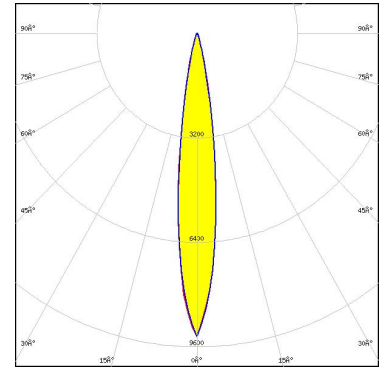

Light distribution files



LED XP-L RGBW HD  
 FWHM / FWTM 23.0° / 39.0°  
 Efficiency 87 %  
 Peak intensity 4.6 cd/lm  
 LEDs/each optic 1  
 Light colour/type RGBW  
 Required components:

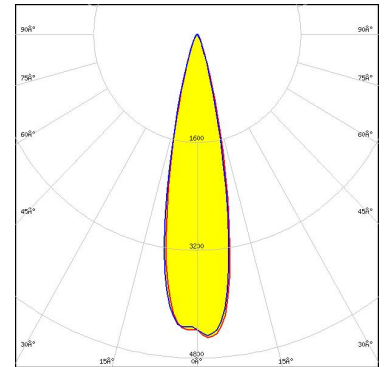

Light distribution files



LED XP-L RGBW HI  
 FWHM / FWTM 16.0° / 32.0°  
 Efficiency 84 %  
 Peak intensity 7.2 cd/lm  
 LEDs/each optic 1  
 Light colour/type RGBW  
 Required components:

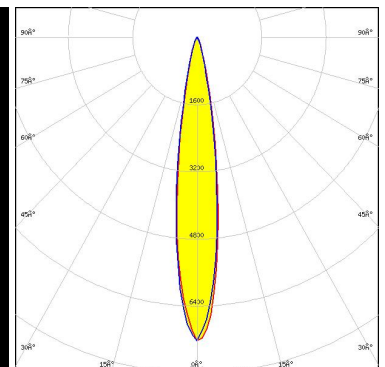
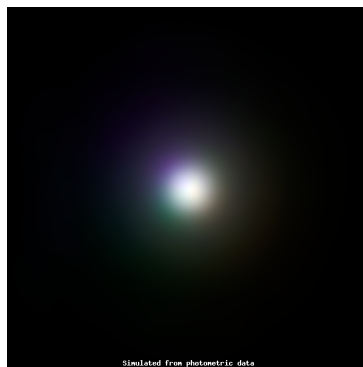

Light distribution files

#### OPTICAL RESULTS (SIMULATED):



LED XP-P  
 FWHM / FWTM 12.0° / 22.0°  
 Efficiency 89 %  
 Peak intensity 15.1 cd/lm  
 LEDs/each optic 1  
 Light colour/type White  
 Required components:

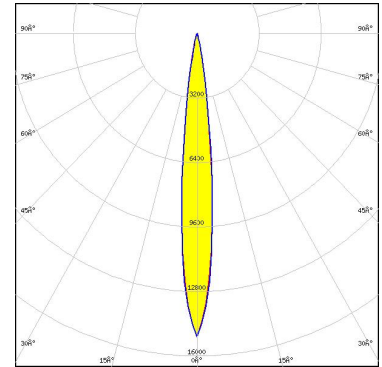

Light distribution files



LED XQ-E HD  
 FWHM / FWTM 12.0° / 24.0°  
 Efficiency 87 %  
 Peak intensity 12.7 cd/lm  
 LEDs/each optic 1  
 Light colour/type White  
 Required components:

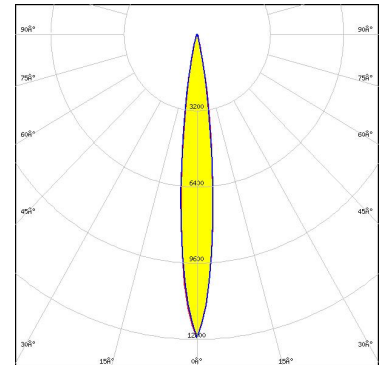

Light distribution files



LED XQ-E HI  
 FWHM / FWTM 12.0° / 22.0°  
 Efficiency 87 %  
 Peak intensity 15.2 cd/lm  
 LEDs/each optic 1  
 Light colour/type White  
 Required components:

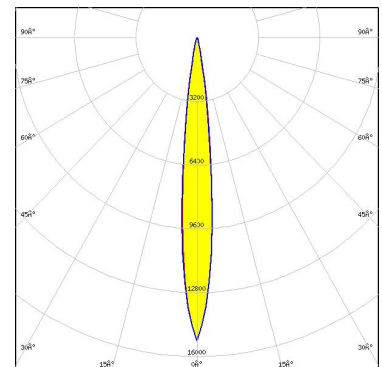

Light distribution files

### OPTICAL RESULTS (SIMULATED):



LED LUXEON 5050 Round LES  
FWHM / FWTM 28.0° / 56.0°  
Efficiency 80 %  
Peak intensity 2.4 cd/lm  
LEDs/each optic 1  
Light colour/type White  
Required components:

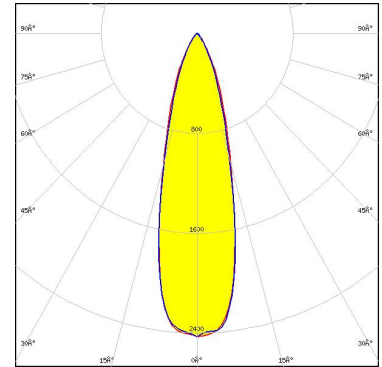

Light distribution files



LED LUXEON 5050 Square LES  
FWHM / FWTM 26.0° / 56.0°  
Efficiency 78 %  
Peak intensity 2.5 cd/lm  
LEDs/each optic 1  
Light colour/type White  
Required components:

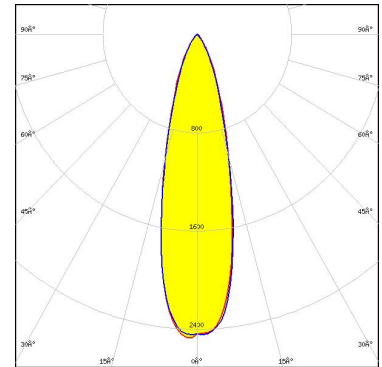

Light distribution files



LED LUXEON C  
FWHM / FWTM 14.0° / 26.0°  
Efficiency 79 %  
Peak intensity 10.8 cd/lm  
LEDs/each optic 1  
Light colour/type White  
Required components:

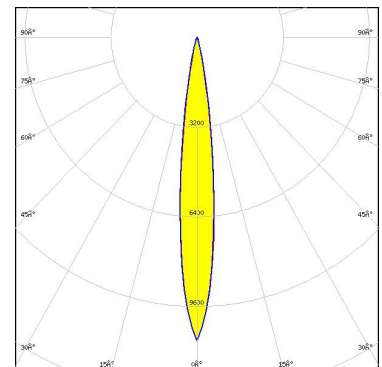

Light distribution files

#### OPTICAL RESULTS (SIMULATED):



LED LUXEON HL2X-V  
 FWHM / FWTM 19.0 + 20.0° / 35.0 + 34.0°  
 Efficiency 89 %  
 Peak intensity 6.3 cd/lm  
 LEDs/each optic 1  
 Light colour/type White  
 Required components:

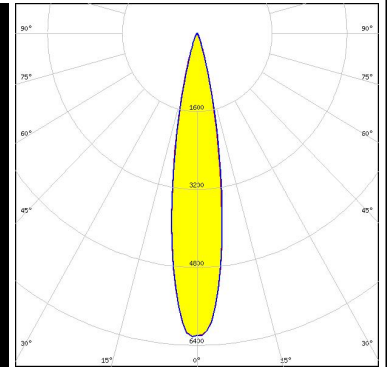
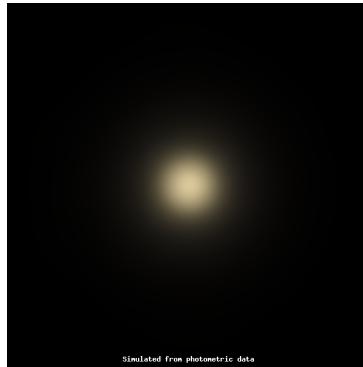

Light distribution files



LED LUXEON MZ  
 FWHM / FWTM 24.0° / 47.0°  
 Efficiency 81 %  
 Peak intensity 3.4 cd/lm  
 LEDs/each optic 1  
 Light colour/type White  
 Required components:

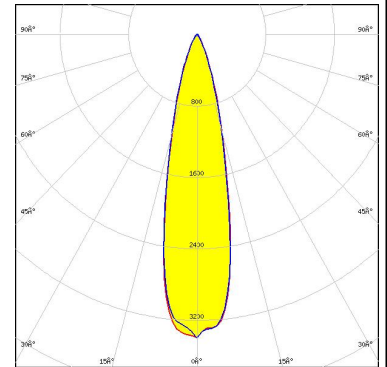

Light distribution files



LED LUXEON TX  
 FWHM / FWTM 15.0° / 30.0°  
 Efficiency 84 %  
 Peak intensity 8 cd/lm  
 LEDs/each optic 1  
 Light colour/type White  
 Required components:

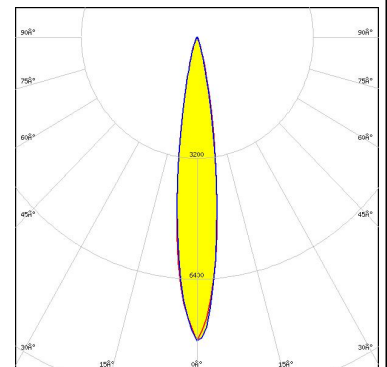

Light distribution files

#### OPTICAL RESULTS (SIMULATED):

**LUMINUS**

LED	SST-20 Gen1
FWHM / FWTM	14.0° / 28.0°
Efficiency	86 %
Peak intensity	9.8 cd/lm
LEDs/each optic	1
Light colour/type	White
Required components:	

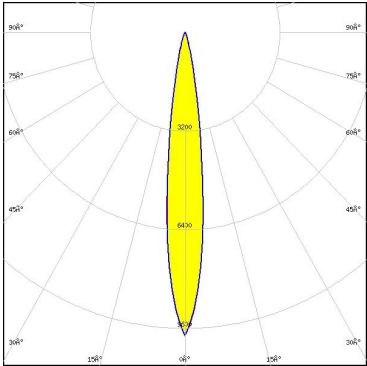

Light distribution files

**LUMINUS**

LED	SST-20 Gen2
FWHM / FWTM	14.0 + 15.0° / 30.0 + 29.0°
Efficiency	86 %
Peak intensity	9.1 cd/lm
LEDs/each optic	1
Light colour/type	White
Required components:	

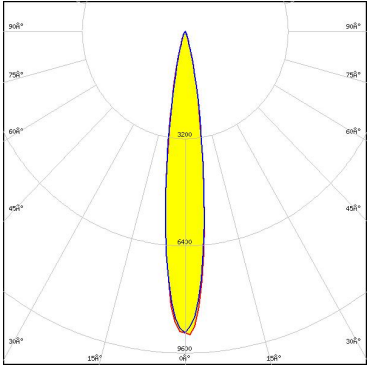
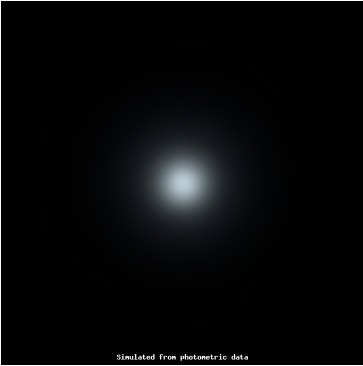
Light distribution files

**LUMINUS**

LED	SST-20F-W
FWHM / FWTM	18.0° / 36.0°
Efficiency	89 %
Peak intensity	6.3 cd/lm
LEDs/each optic	1
Light colour/type	White
Required components:	



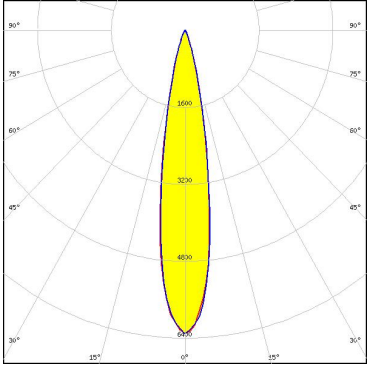
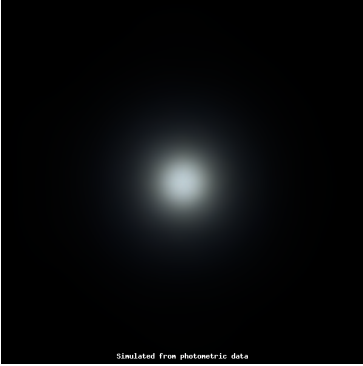

Light distribution files

#### OPTICAL RESULTS (SIMULATED):

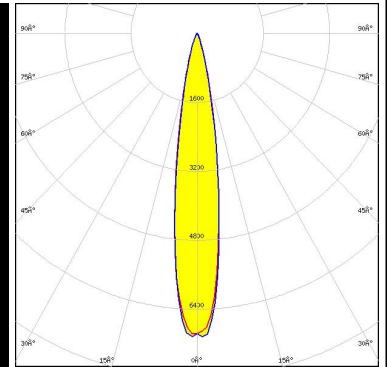
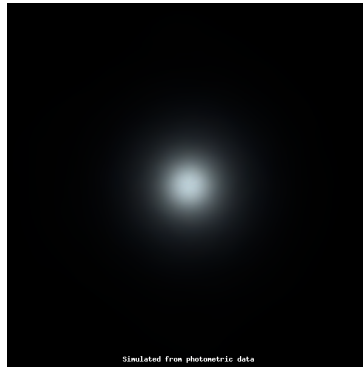

**LED** SST-25-W  
**FWHM / FWTM** 18.0 + 16.0° / 34.0°  
**Efficiency** 86 %  
**Peak intensity** 7.1 cd/lm  
**LEDs/each optic** 1  
**Light colour/type** White  
**Required components:**



Light distribution files



**LED** SST-36F-W  
**FWHM / FWTM** 24.0° / 43.0 + 44.0°  
**Efficiency** 87 %  
**Peak intensity** 4.2 cd/lm  
**LEDs/each optic** 1  
**Light colour/type** White  
**Required components:**

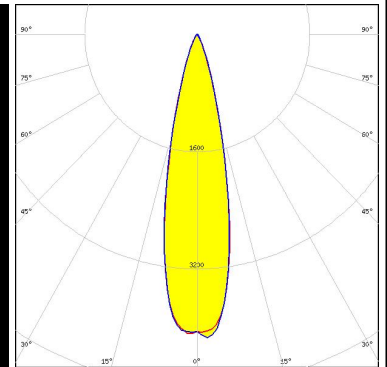

Light distribution files



**LED** NV4WB35AM  
**FWHM / FWTM** 24.0° / 46.0°  
**Efficiency** 85 %  
**Peak intensity** 3.7 cd/lm  
**LEDs/each optic** 1  
**Light colour/type** White  
**Required components:**

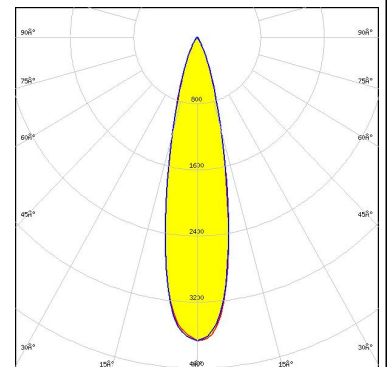

Light distribution files

### OPTICAL RESULTS (SIMULATED):



LED NVSW219C-V2  
FWHM / FWTM 14.0° / 26.0°  
Efficiency 88 %  
Peak intensity 11.3 cd/lm  
LEDs/each optic 1  
Light colour/type White  
Required components:

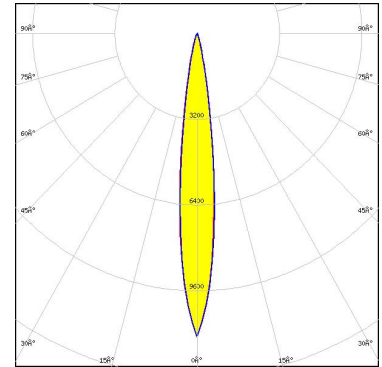

Light distribution files



LED NVSW219F  
FWHM / FWTM 18.0° / 33.0°  
Efficiency 87 %  
Peak intensity 6.6 cd/lm  
LEDs/each optic 1  
Light colour/type White  
Required components:

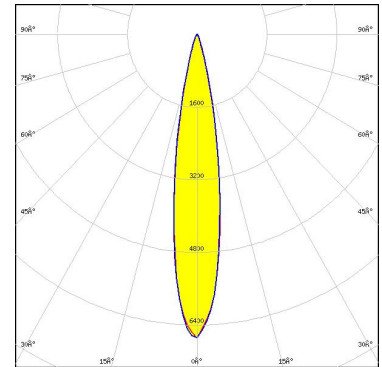

Light distribution files



LED NVSxE21A  
FWHM / FWTM 16.0° / 34.0°  
Efficiency 79 %  
Peak intensity 7 cd/lm  
LEDs/each optic 1  
Light colour/type White  
Required components:

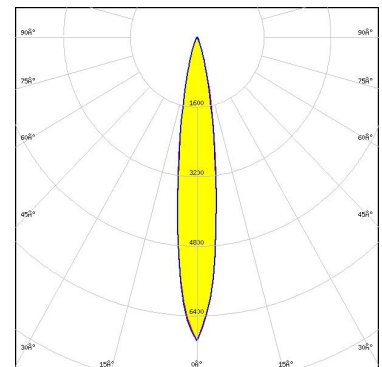

Light distribution files

#### OPTICAL RESULTS (SIMULATED):

**OSRAM**  
Opto Semiconductors

LED OSLON Pure 1414  
 FWHM / FWTM 12.0° / 22.0°  
 Efficiency 89 %  
 Peak intensity 15.9 cd/lm  
 LEDs/each optic 1  
 Light colour/type White  
 Required components:

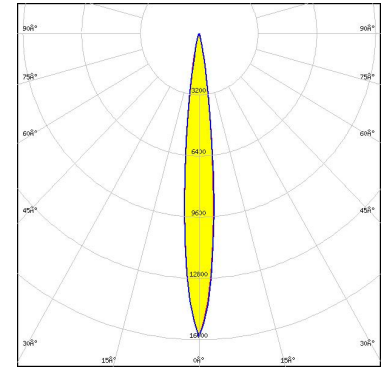

Light distribution files

**OSRAM**  
Opto Semiconductors

LED OSLON Square CSSRM2/CSSRM3  
 FWHM / FWTM 16.0° / 32.0°  
 Efficiency 86 %  
 Peak intensity 7.5 cd/lm  
 LEDs/each optic 1  
 Light colour/type White  
 Required components:

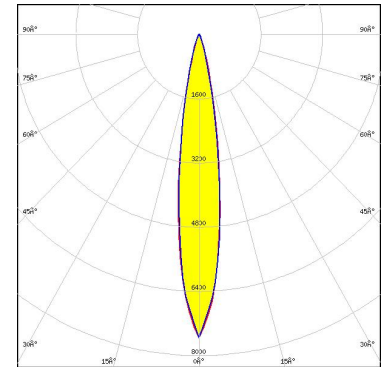

Light distribution files

**OSRAM**  
Opto Semiconductors

LED OSLON SSL 150  
 FWHM / FWTM 13.0° / 25.0°  
 Efficiency 88 %  
 Peak intensity 13 cd/lm  
 LEDs/each optic 1  
 Light colour/type White  
 Required components:

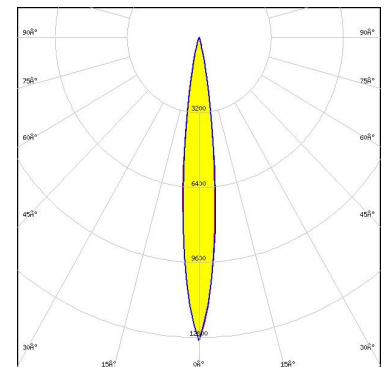

Light distribution files

#### OPTICAL RESULTS (SIMULATED):

**OSRAM**  
Opto Semiconductors

LED SFH 4715AS  
FWHM / FWTM 16.0° / 33.0°  
Efficiency 86 %  
LEDs/each optic 1  
Light colour/type IR  
Required components:

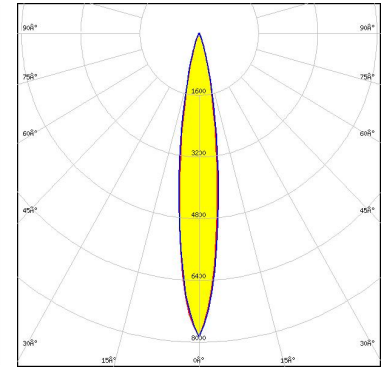
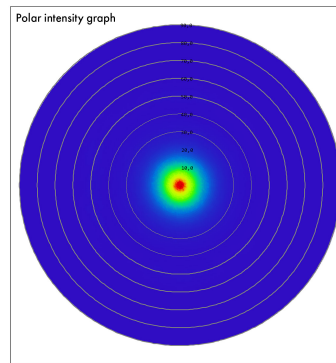

Light distribution files

**OSRAM**  
Opto Semiconductors

LED SFH 4725AS  
FWHM / FWTM 16.0° / 34.0°  
Efficiency 86 %  
LEDs/each optic 1  
Light colour/type IR  
Required components:

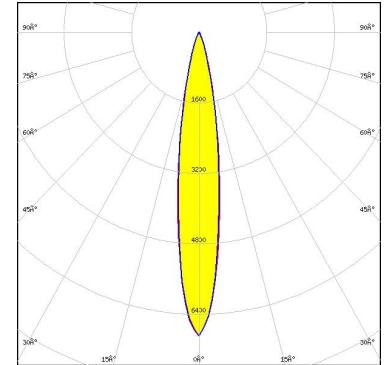
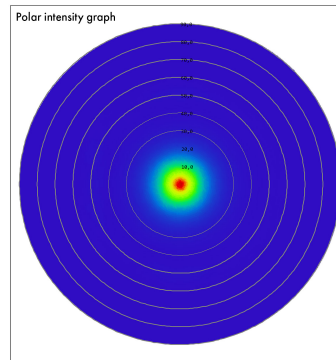

Light distribution files

**SAMSUNG**

LED LH351C  
FWHM / FWTM 19.0° / 36.0°  
Efficiency 87 %  
Peak intensity 5.9 cd/lm  
LEDs/each optic 1  
Light colour/type White  
Required components:

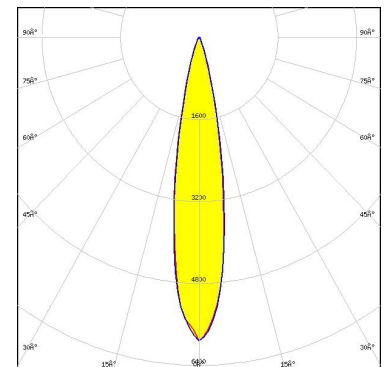

Light distribution files

### GENERAL INFORMATION:

NOTE: The typical beam angle will be changed by different color, chip size and chip position tolerance. The typical total beam angle is the full angle measured where the luminous intensity is half of the peak value.

### MATERIALS:

As part of our continuous research and improvement processes, and to ensure the best possible quality and availability of our products, LEDiL reserves the right to change material grades without notice.

### PRODUCT DATA USER AGREEMENT AND DISCLAIMER:

The measured data in the provided downloadable LEDiL Product Datasheets and Mechanical 2D-Drawings is rounded and provided as reference for planning. LEDiL Oy's optical specifications have been verified by conducting performance testing of the products in accordance with the company's quality system. The reported data are averaged results of multiple measurements with typical variation. LEDiL Oy reserves the right to without prior notification make changes and improvements to its products.

LEDiL Oy assumes neither warranty, nor guarantee nor any other liability of any kind for the contents and correctness of the provided data. The provided data has been generated with highest diligence but the provided data may in reality not represent the complete possible variation range of all intrinsic parameters. Therefore, in certain cases a deviation from the provided data could occur.

LEDiL Oy reserves the right to undertake technical changes of its products without further notification which could lead to changes in the provided data. LEDiL Oy assumes no liability of any kind for the possible deviation from any provided data or any other damage resulting from the usage of the provided data.

The user agrees to this disclaimer and user agreement with the download or usage of the provided files.

#### LEDiL Oy

Joensuunkatu 7  
FI-24240 SALO  
Finland

#### LEDiL Inc.

228 West Page Street  
Suite D  
Sycamore IL 60178  
USA

#### Ledil Optics Technology (Shenzhen) Co., Ltd.

# 405 , Block B  
Casic Motor Building  
Shenzhen 518057  
P.R.CHINA

#### Local sales and technical support

[www.ledil.com/  
where\\_to\\_buy](http://www.ledil.com/where_to_buy)

#### Shipping locations

Poznan, Poland  
Hong Kong, China

#### Distribution Partners

[www.ledil.com/  
where\\_to\\_buy](http://www.ledil.com/where_to_buy)